

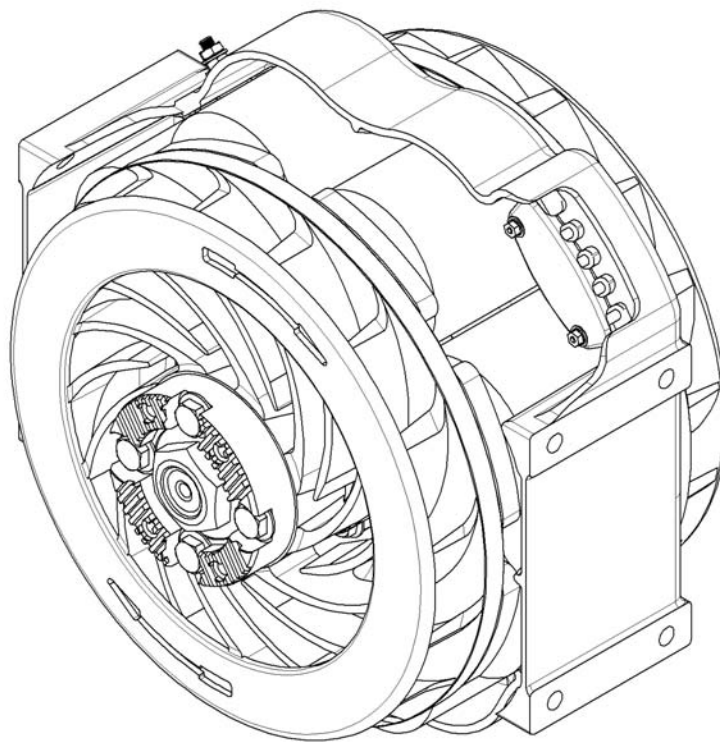

Produced by Industrias Zelu

CFK-65 MODEL TECHNICAL SPECIFICATIONS



DRIVELINE RETARDER

CFK-65



Produced by Industrias Zelu

CFK-65 MODEL TECHNICAL SPECIFICATIONS

• SPECIFICATIONS

Application Range (GVW)		4 - 6,5 t / 8800 – 14300 lb
Maximum braking torque	12V	638 Nm / 471 lb-ft
	24V	690 Nm / 509 lb-ft
WEIGHT (no brackets)	Complete	130 Kg / 287 lb
	Stator	94 / 207 lb
	Rotors	36 Kg / 80 lb
Rotors Inertia		0.98 Kg ^m / 23 lb-ft ²
Maximum transmissible torque		10000 Nm / 7380 lb-ft
Max. admissible R.P.M. (min ⁻¹)	Constant	4000
	Periodic	5300
Air-gap regulation (±0.1 mm / ±0.0039 inch.)		1 mm / 0.0394 inch

• PERFORMANCE CURVES

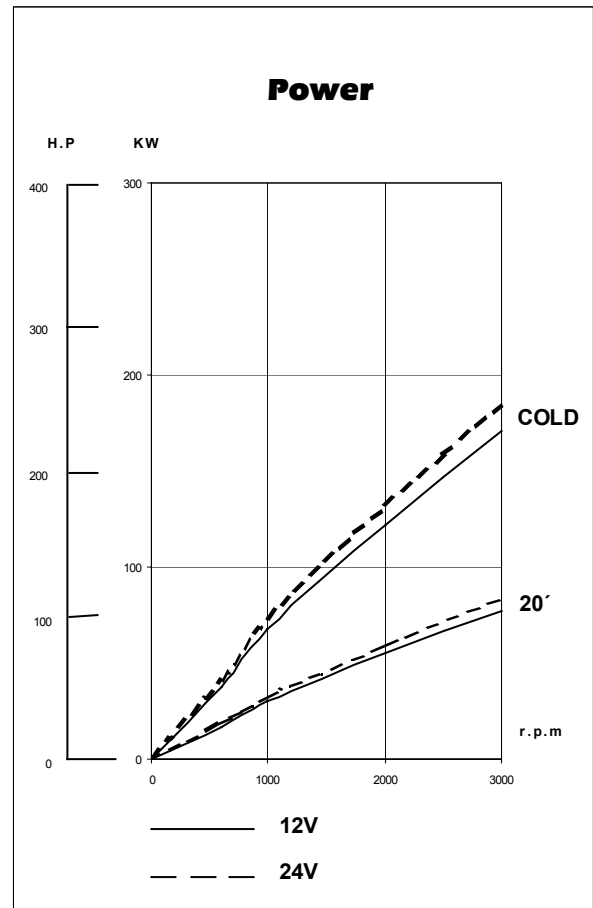
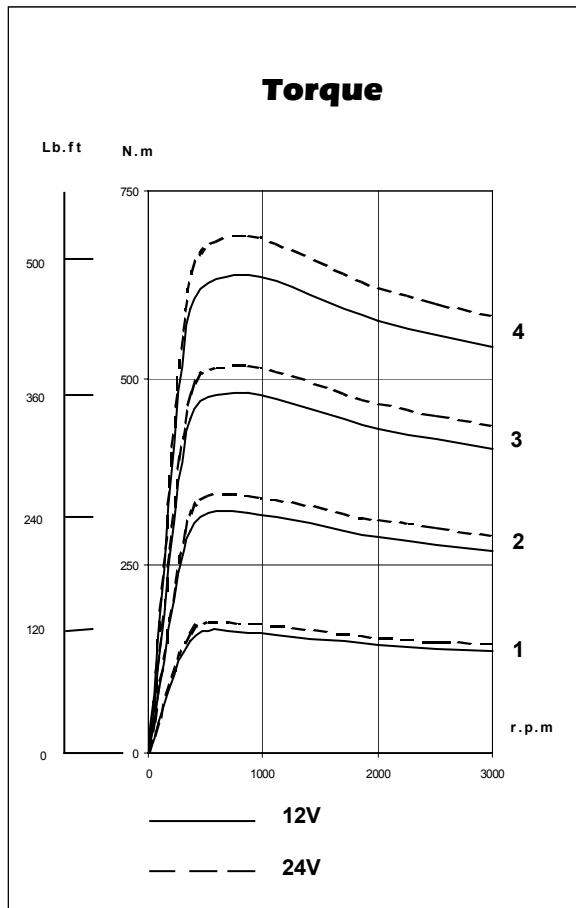



Produced by Industrias Zelu

CFK-65 MODEL DIMENSIONS

• DIMENSIONS

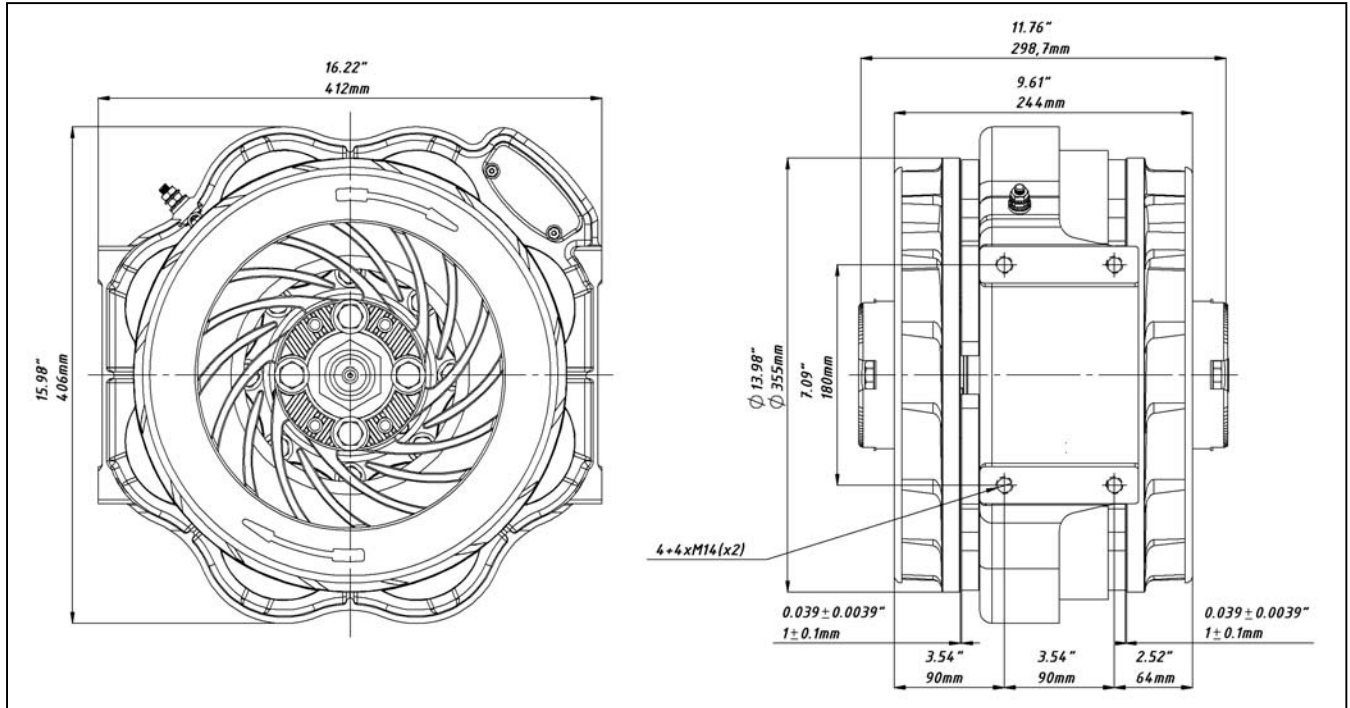

• MAIN COMPONENTS

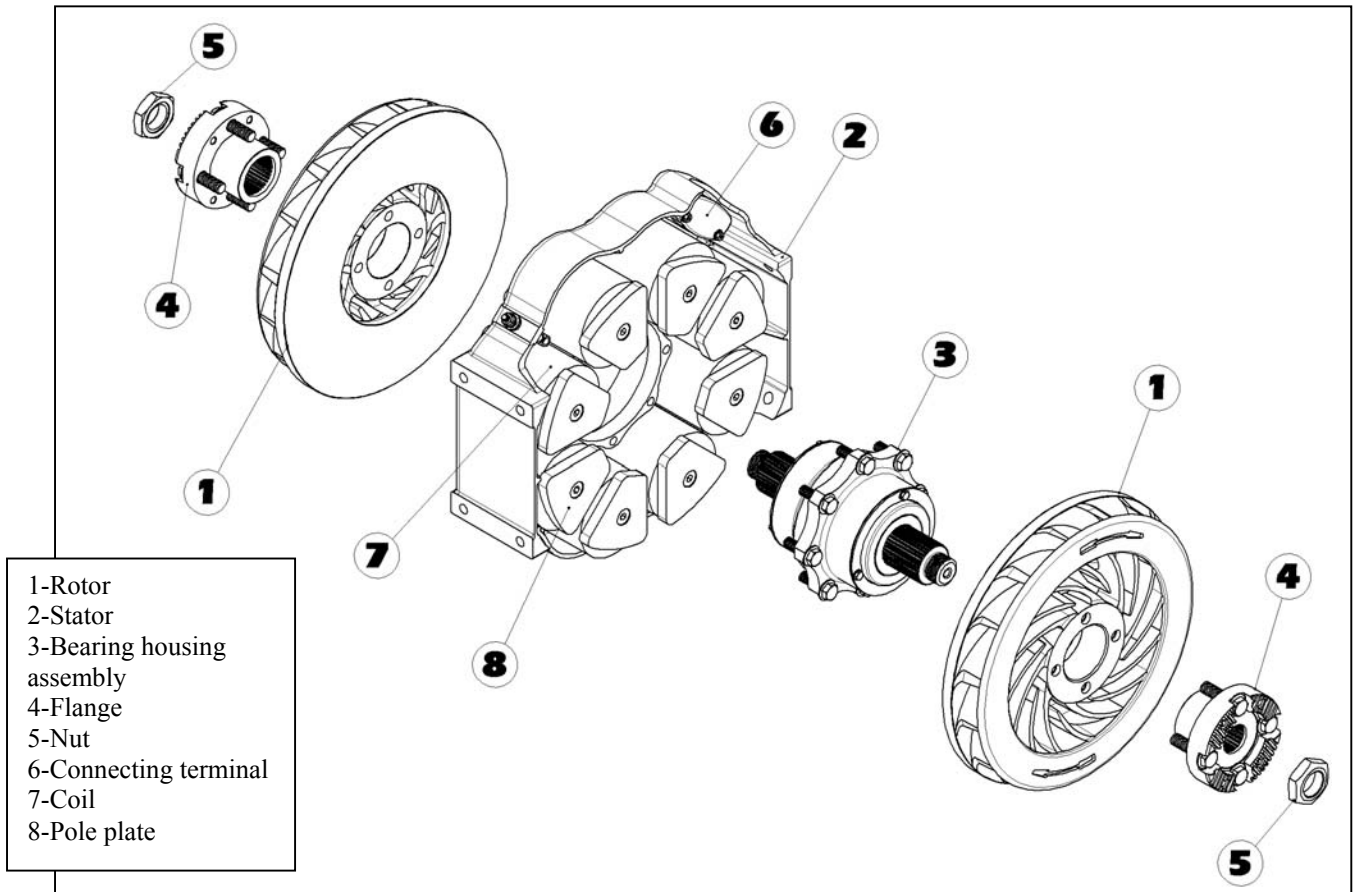



Produced by Industrias Zelu

CFK-65 MODEL ELECTRICAL SPECIFICATIONS

• ELECTRICAL SPECIFICATIONS

Voltage (depending on vehicle equipment)	12 V	24 V
Resistance per circuit (Ω) $\pm 5\%$ (20°C)	0.42	1.3
Resistance per coil (Ω) $\pm 5\%$ (20°C)	0.85	2.6
Consumption per circuit (A) $\pm 5\%$ (20°C)	28	18
Insulation resistance (M Ω)	1	

• INTERNAL WIRING DIAGRAM

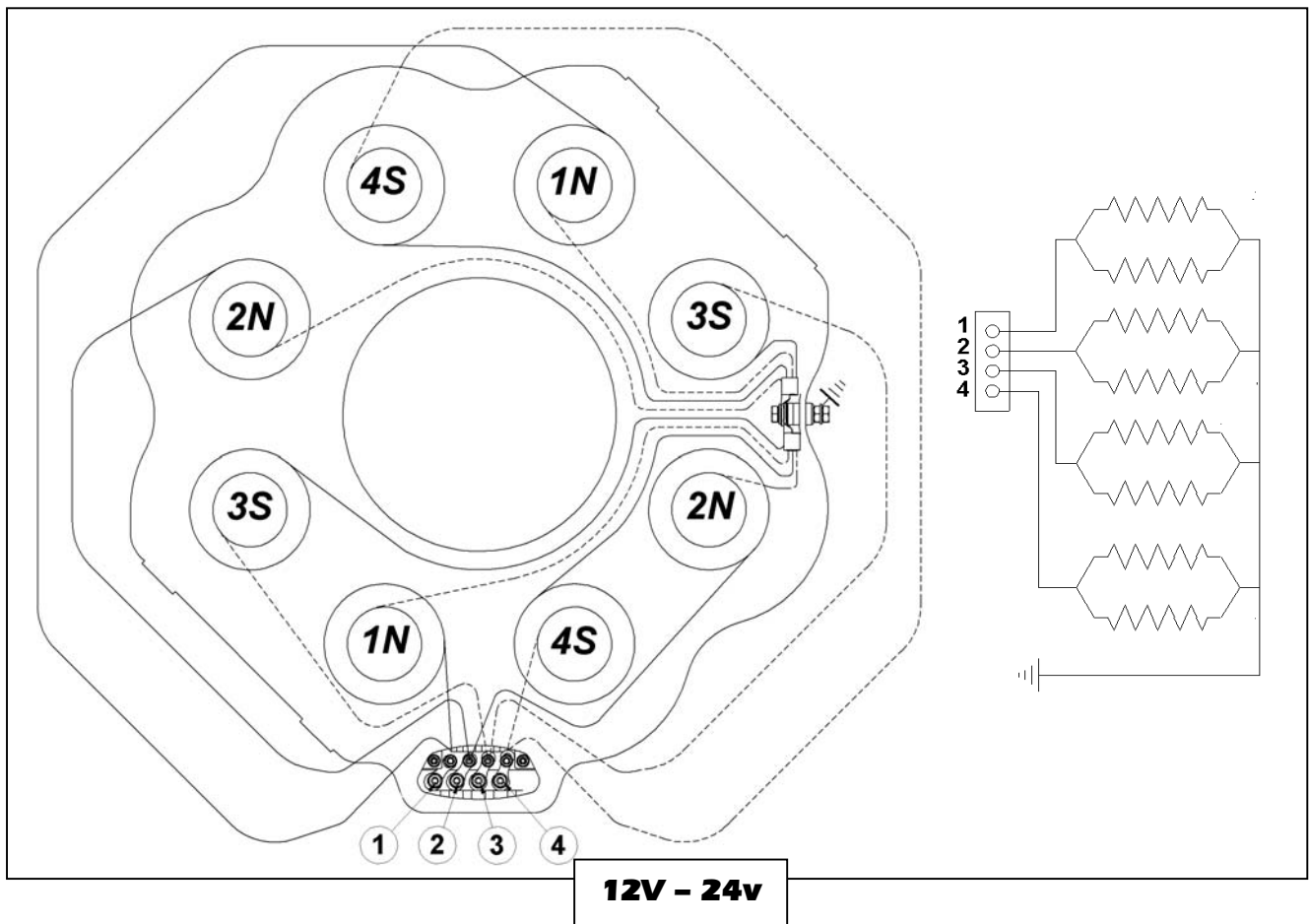

Wiring of 12 and 24 VDC version is equal, only the coil is different



Produced by Industrias Zelu

CFK-65 MODEL BRACKET OPTION

Internal brackets with "CO"

Silentblock.

Usually used in wide chassis.

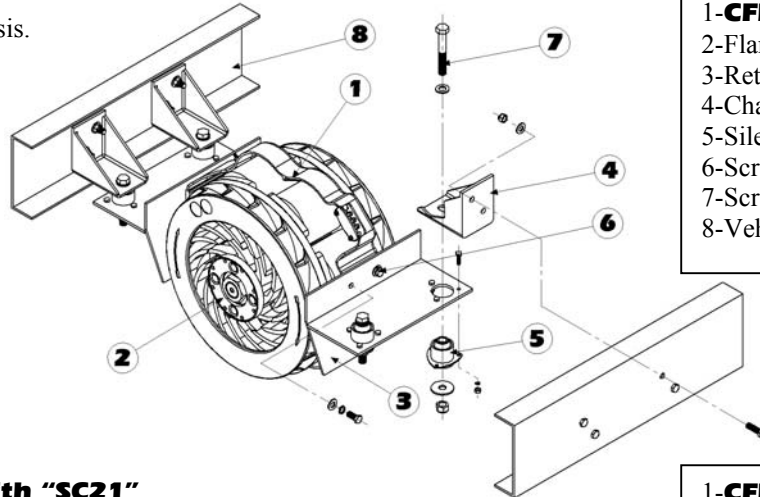

1-CFK-65.

- 2-Flange.
- 3-Retarder bracket (2 uni.)
- 4-Chassis bracket (4 uni.)
- 5-Silentblock "CO" (4 uni.)
- 6-Screw M14 120 Nm $\pm 5\%$
- 7-Screw M18(x1.5) 290 Nm $\pm 5\%$
- 8-Vehicle chassis.

Internal brackets with "SC21"

Silentblock.

Usually used in narrow chassis.

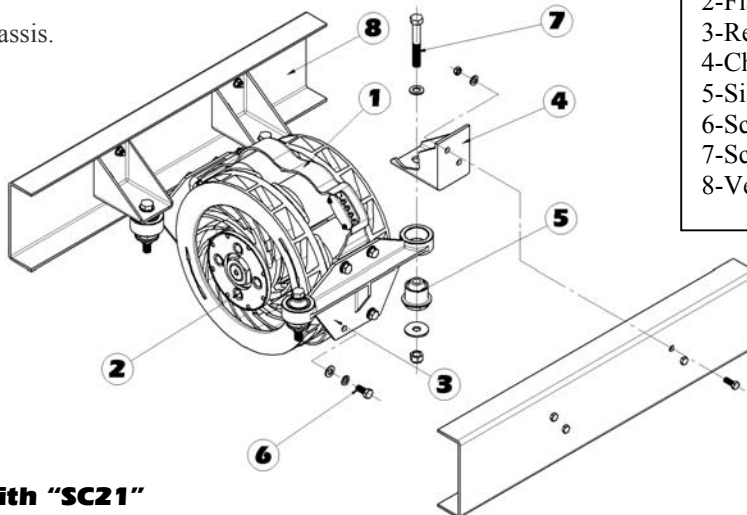

1-CFK-65.

- 2-Flange.
- 3-Retarder bracket (2 uni.)
- 4-Chassis bracket (4 uni.)
- 5-Silentblock "SC21" (4 uni.)
- 6-Screw M14 120 Nm $\pm 5\%$
- 7-Screw M18(x1.5) 290 Nm $\pm 5\%$
- 8-Vehicle chassis.

External brackets with "SC21"

Silentblock.

Usually used in chassis where the original elements of the vehicle prevent using the previous mentioned.

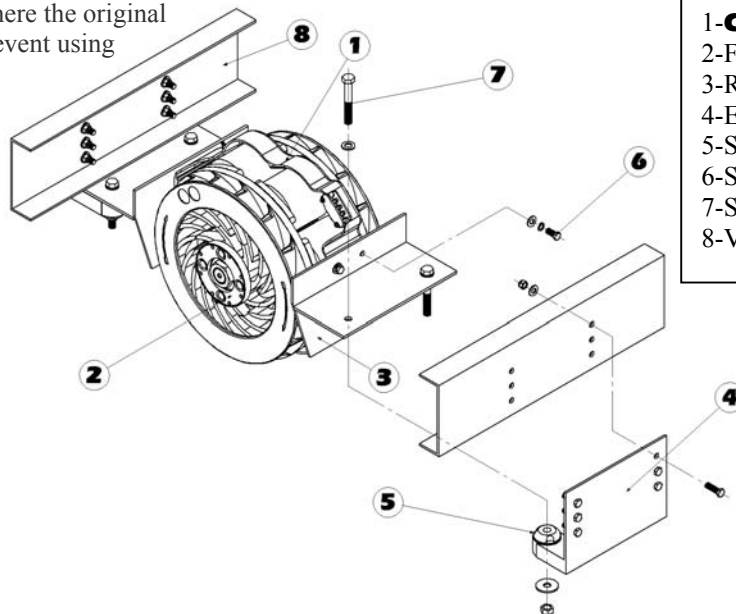

1-CFK-65.

- 2-Flange.
- 3-Retarder bracket (2 uni.)
- 4-External Chassis bracket (2 uni.)
- 5-Silentblock "SC21" (4 uni.)
- 6-Screw M14 120 Nm $\pm 5\%$
- 7-Screw M18(x1.5) 290 Nm $\pm 5\%$
- 8-Vehicle chassis.



Produced by Industrias Zelu

INDUSTRIAS ZELU S.L.

Ctra. de Irún Km 6,5
31194 ARRE (Navarra) SPAIN

☎ ++ 34 - 948 33 11 01 ☆ **FAX** ++ 34 - 948 33 11 51

e-mail: industrias@zelusl.com
Visit our Website: www.zelusl.com

This space is reserved for our dealers